

265W FAN COOLED 180W CONVECTION COOLED

AC-DC POWER SUPPLIES

The GCS265 is a series of medical AC-DC power supplies with 265W fan cooled and 180W convection rating.

Designed to minimize no load power consumption, the GCS265 series of high efficiency, single-output power supplies are packaged in a 5.0" x 3.5" x 1.43" package making them suitable for medical, industrial, information technology and domestic applications. Class I and Class II versions are available, allowing use in professional healthcare facilities such as hospitals and remotely in patients' homes or workplaces.

GCS265 also features a DC OK signal for remote monitoring, remote On/Off and a 5VDC/3A isolated auxiliary supply. With a wide range of international medical safety and ITE approvals, class B compliance for conducted and class A radiated emissions, very low earth leakage currents, and 2 x MOPP protection, the GCS265 benefits system designers with easy integration into a wide range of applications.



Applications



Healthcare



Home Healthcare



Industrial Electronics



Instrumentation



Technology

Features

- Single outputs from 12V to 48VDC
- Universal 85 to 264VAC input range
- High efficiency – up to 93%
- ITE and medical safety approvals (Class I & II)
- 4kVAC input to output isolation
- Class B conducted emissions
- 5V/3A Standby Output
- Remote on/off option, remote sense and DC OK signal
- Overcurrent, overvoltage and short-circuit protection
- Operating temperature range from -40°C to +70°C

Dimensions

GCS265:

5.00 x 3.50 x 1.43" (127.0 x 88.8 x 36.3 mm)

(-C): 5.50 x 4.01 x 1.72" (139.7 x 101.8 x 43.7 mm)

(-TF): 5.50 x 3.48 x 2.20" (139.7 x 88.5 x 57.8 mm)

(-EF): 6.35 x 3.48 x 1.70" (161.3 x 88.5 x 43.2 mm)

Models & Ratings

Model Number ^(1,2,3)	Output Voltage V1	Output Current V1		V Standby Output		Output Voltage (Vfan) & Current	Max Output Power
		Convection-cooled	Forced-cooled	Convection-cooled	Forced-cooled		
GCS265PS12	12.0VDC	15.0A	20.8A	5.0VDC/2.0A	5.0VDC/3.0A	12.0VDC/0.6A	265W
GCS265PS15	15.0VDC	12.0A	16.7A	5.0VDC/2.0A	5.0VDC/3.0A	12.0VDC/0.6A	265W
GCS265PS24	24.0VDC	7.5A	10.4A	5.0VDC/2.0A	5.0VDC/3.0A	12.0VDC/0.6A	265W
GCS265PS28	28.0VDC	6.4A	8.9A	5.0VDC/2.0A	5.0VDC/3.0A	12.0VDC/0.6A	265W
GCS265PS48	48.0VDC	3.7A	5.2A	5.0VDC/2.0A	5.0VDC/3.0A	12.0VDC/0.6A	265W

Notes:

1. To order power supply with optional cover fitted add suffix '-C' to model number, e.g. GCS265PS24-C. Derate to 150W when convection cooled.
2. To order power supply with optional Top Fan Cover fitted add suffix '-TF' to model number, e.g. GCS265PS24-TF
3. To order power supply with optional End Fan Cover fitted add suffix '-EF' to model number, e.g. GCS265PS24-EF

Summary

Characteristic	Minimum	Typical	Maximum	Units	Notes & Conditions
Input Voltage Range	85	115/230	264	VAC	Derate output power <90VAC. See fig. 1
No Load Input Power		5.6		W	115VAC
		4.2			230VAC
			0.5		When inhibit is activated
Efficiency		93		%	230VAC Full load (see fig.3-5)
Operating Temperature	-40		+70	°C	See derating curve, fig. 8
EMC	EN55011/32 Level B Conducted & Level A Radiated, EN61000-3-3				
Safety Approvals	IEC62368-1, IEC60950-1, IEC60601-1, UL62368-1, CAN/CSA C22.2 No. 62368-1-14, ANSI/AAMI ES60601-1, CSA C22.2, No.60601-1, EN62368-1, EN60601-1				

Input

Characteristic	Minimum	Typical	Maximum	Units	Notes & Conditions
Input Voltage Range	85	115/230	264	VAC	Derate output power at 90VAC. See fig. 1
Input Frequency	47	50/60	63	Hz	
Power Factor		>0.9			230VAC, 100% load
Input Current - Full Load		2.6/1.3		A	115/230VAC
Inrush Current		80		A	230VAC, cold start 25°C
Earth Leakage Current		95/185	250	µA	115/230VAC/50Hz Typ., 264VAC/60Hz max.
No Load Input Power		5.6		W	115VAC
		4.2			230VAC
			0.5		When inhibit is activated
Input Protection	F5.0 A/250V internal fuse in both lines				

Input Voltage Derating Curve

Figure 1

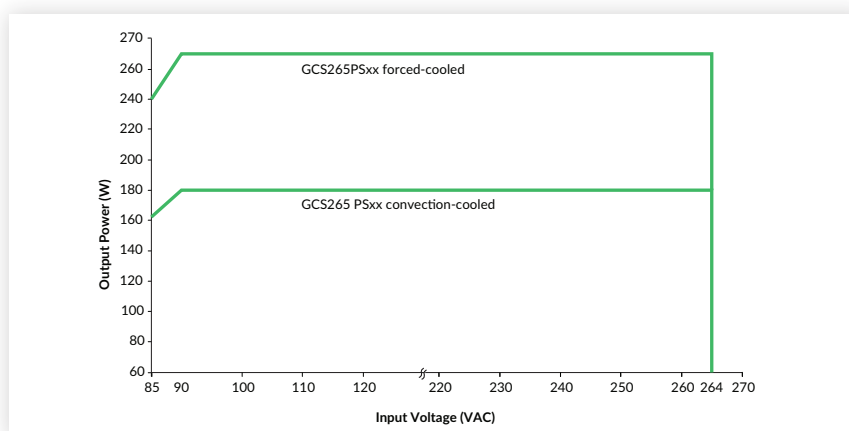

Output

Characteristic	Minimum	Typical	Maximum	Units	Notes & Conditions
Output Voltage - V1	12		48	VDC	See Models & Ratings table
Initial Set Accuracy			$\pm 1^{(V1)}$ & $\pm 5^{(Vfan)}$	%	50% load, 115/230VAC
Output Voltage Adjustment - V1	± 2			%	Via potentiometer. See mech. details, Vfan will track
Minimum Load	0			A	No minimum load required
Start Up Delay			0.5	s	115/230VAC, full load
Hold Up Time		10		ms	115/230VAC, full load
Drift			± 0.2	%	After 20 min warm up
Line Regulation			± 0.5	%	90-264VAC
Load Regulation			$\pm 0.5^{(V1)}$, $\pm 5^{(Vfan)}$	%	0-100% load
Transient Response - V1			4	%	Recovery within 1% in less than 500 μ s for a 50-75% and 75-50% load step
Over/Undershoot -V1		5	5.1	%	
Ripple & Noise -V1			1	% pk-pk	20MHz bandwidth, 12V models 1.5% max.
Overvoltage Protection - V1	110		140	%	Vnom DC. Output 1, recycle input to reset
Overload Protection - V1	110		150	% I nom	See fig. 2. Trip & restart
Short Circuit Protection - V1					Continuous
Temperature Coefficient			0.05	%/°C	
Overtemperature Protection				°C	Not fitted
Output Voltage - V3		5		VDC	
Initial Set Accuracy - V3		2		%	50% load, 115/230VAC
Output Voltage Adjustment - V3		n/a		%	
Minimum Load - V3		0		A	No minimum load required
Line Regulation - V3		1		%	90-264VAC
Load Regulation - V3		2		%	0-100% load
Transient Response - V3		4		%	Recovery within 1% in less than 500 μ s für a 50 - 75% and 75-50% load step
Ripple & Noise - V3		2		%pk-pk	20MHz bandwidth
		1		%RMS	
Overvoltage Protection - V3		n/a			
Overcurrent Protection - V3	110		170	% Inom	

Output Overload Characteristic

Figure 2
GCS265PS12 example (others similar)

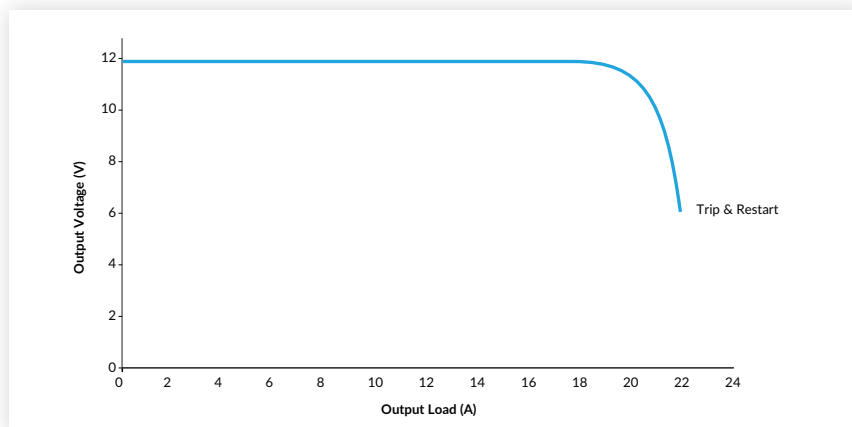

General

Characteristic	Minimum	Typical	Maximum	Units	Notes & Conditions
Efficiency		93		%	230VAC Full load (see fig.3-5)
Isolation: Input to Output	4000			VAC	
Input to Ground	1500				
Output to Ground	1500				
Switching Frequency	60		200	kHz	PFC
	90		150		Main converter
Power Density			10.7	W/in ³	
Mean Time Between Failure		346		khrs	MIL-HDBK-217F, Notice 2 +25°C GB
Weight		0.71 (320)		lb (g)	For open frame version. See mechanical details for weights of other formats

Efficiency Graphs

Efficiency vs Load

Figure 3
GCS265PS12

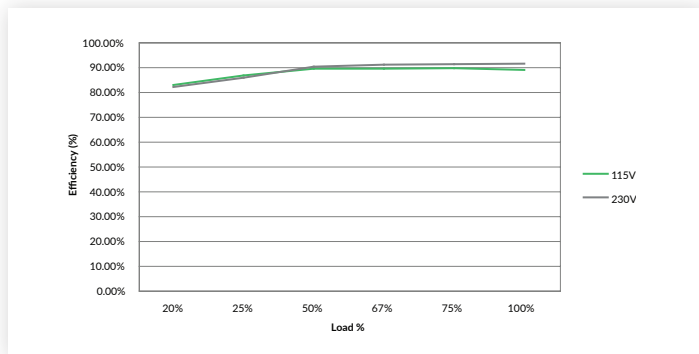

Figure 4
GCS265PS24

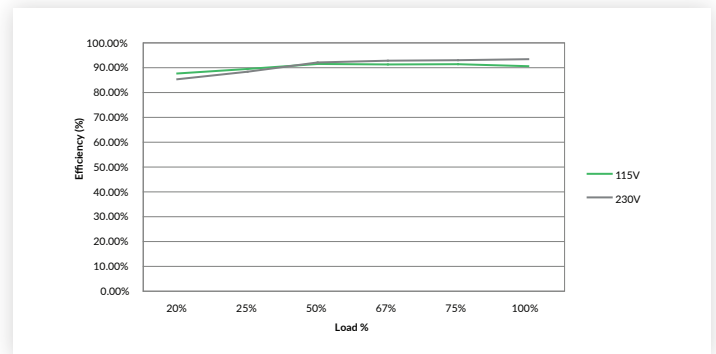
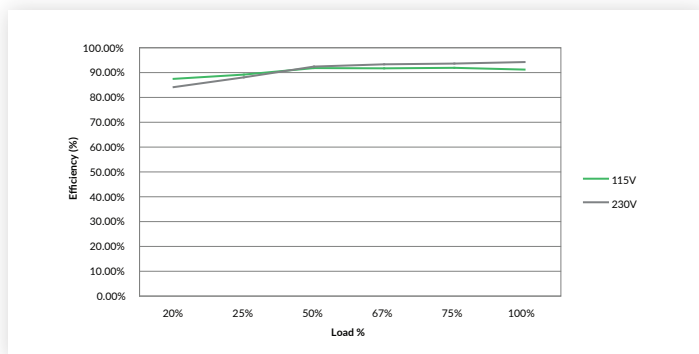

Figure 5
GCS265PS48



Signals & Controls

Characteristic	Notes & Conditions	
Power OK (DC-OK)	Collector pin 6 is internally tied via 10k resistor to +V standby and referenced to -V standby pins 9 & 10 of J4. Provides ≥ 2 ms warning of loss of output from AC failure.	
Standby Supply	5 VDC/3.0 A Isolated supply present when AC applied.	
Remote Sense	Compensates for 0.5V total voltage drop	
Remote On/Off	Inhibit	The inhibit lo (pin 4), should be pulled below 0.4V to switch V1 & Vf an off. Open circuit or $>4V$ to switch on (see fig. 7)
	Enable	With the inhibit lo (pin 4) pulled low as detailed above, connecting inhibit hi (pin 5) to inhibit lo (pin 4) will enable V1 & V fan output. (see fig. 8)

Power OK (DC-OK)

Figure 6

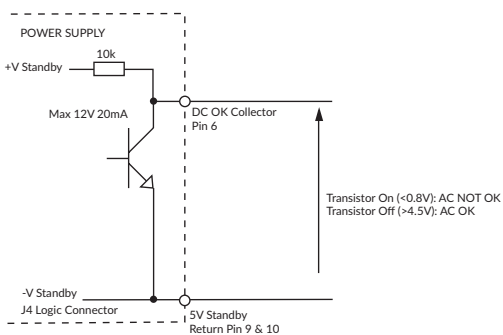

Remote On/Off (Inhibit)

Figure 7

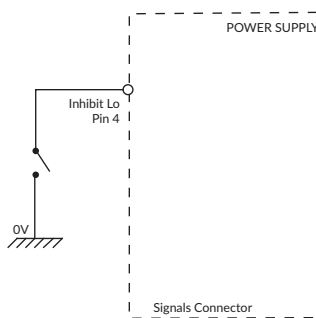

Remote On/Off (Enable)

Figure 8

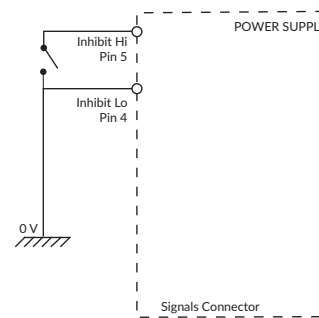

Environmental

Characteristic	Minimum	Typical	Maximum	Units	Notes & Conditions
Operating Temperature	-40		+70	°C	See derating curves, fig. 9
Storage Temperature	-40		+85	°C	
Cooling	7			CFM	Forced-cooled >180W
Humidity	5		95	%RH	Non-condensing
Operating Altitude			5000	m	
Shock	$\pm 3 \times 30g$ shocks in each plane, total 18 shocks. 30g = 11ms (± 0.5 msec), half sine. Conforms to EN60068-2-27 & EN60068-2-47				
Vibration	Single axis 10-500 Hz at 2g sweep and endurance at resonance in all 3 planes. Conforms to EN60068-2-6				

Temperature Derating Curve

Figure 9

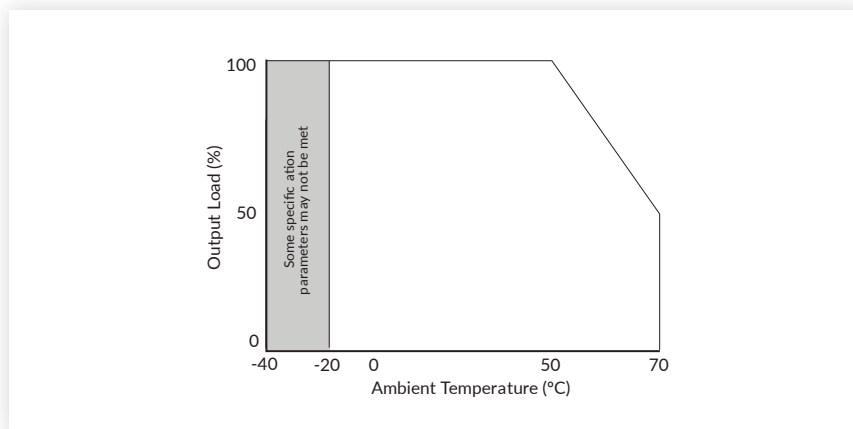

EMC: Emissions

Phenomenon	Standard	Test Level	Notes & Conditions
Conducted	EN55011/32	Class B	
Radiated	EN55011/32	Class A	
Harmonic Fluctuations	EN61000-3-3		

EMC: Immunity

Phenomenon	Standard	Test Level	Criteria	Notes & Conditions	
Low Voltage PSU EMC	EN61204-3	High severity level	as below		
Harmonic Current	EN61000-3-2	Class A		All models	
		Class C		>70W	
Radiated	EN61000-4-3	3	A		
EFT	EN61000-4-4	3	A		
Surges	EN61000-4-5	Installation class 3	A		
Conducted	EN61000-4-6	3	A		
Dips and Interruptions	EN55035 (100VAC)	Dip >95% (0VAC), 8.3ms	A		
		Dip 30% (70VAC), 416ms	B		
		Dip >95% (0VAC), 4160ms	B		
	EN55035 (240VAC)	Dip >95% (0VAC), 10.0ms	A		
		Dip 30% (168VAC), 500ms	B		
		Dip >95% (0VAC), 5000ms	B		
	EN60601-1-2 (100VAC)	Dip >95% (0VAC), 10.0ms	A		
		Dip 60% (40VAC), 100ms	A		Derate Output Power to 120W
		Dip 30% (70VAC), 500ms	A		
		Dip >95% (0VAC), 5000ms	B		
	EN60601-1-2 (240VAC)	Dip >95% (0VAC), 10.0ms	A		
		Dip 60% (96VAC), 100ms	A		
Dip 30% (168VAC), 500ms		A			
Dip >95% (0VAC), 5000ms		B			

Safety Approvals

Certification	Standard	Notes & Conditions
CB	IEC60950-1:2005 Ed 2 / IEC62368-1:2014	Information Technology
	IEC60601-1 Ed 3.1 Including Risk Management	Medical
UL	UL62368-1 & CAN/CSA C22.2 No. 62368-1-14	Information Technology
	ANSI/AAMI ES60601-1:2005 & CSA C22.2, No.60601-1:08	Medical
TUV	EN62368-1:2014/A11:2017	Information Technology
	EN60601-1/A12:2016	Medical
Equipment Protection Class	Class I & Class II	See safety agency conditions of acceptability for details
CE	Meets all applicable directives	
UKCA	Meets all applicable legislation	
Isolation	Means of Protection	Category
Primary to Secondary	2 x MOPP (Means of Patient Protection)	IEC60601-1
Primary to Earth	1 x MOPP (Means of Patient Protection)	IEC60601-1
Secondary to Earth	1 x MOPP (Means of Patient Protection)	IEC60601-1

Mechanical Details

Open Frame

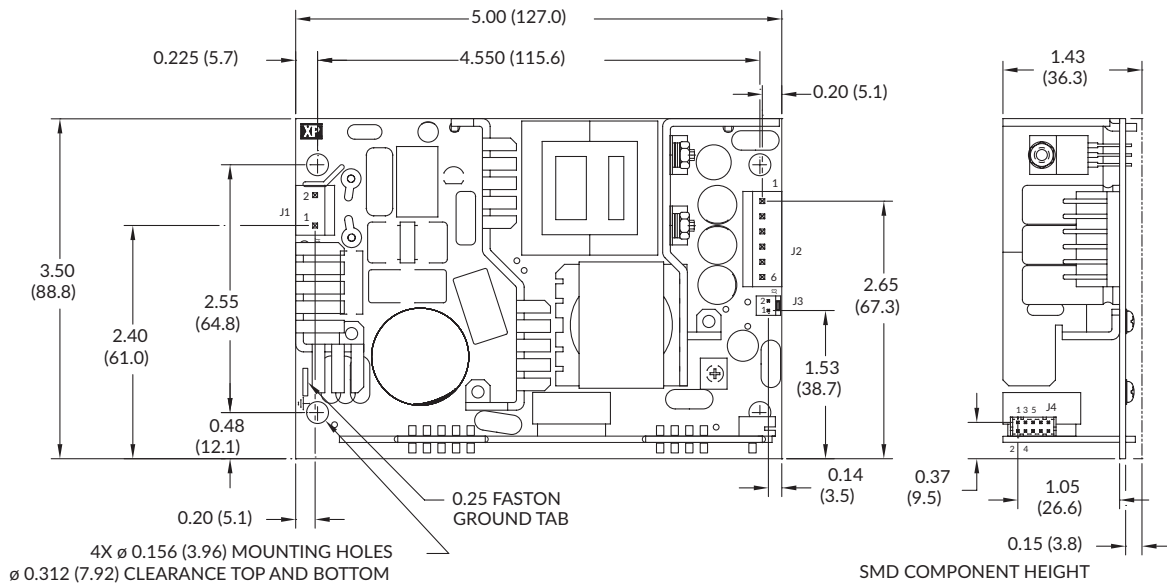

Input Connector J1 Molex pn. 09-65-2038	
Pin	Function
1	Line
2	Neutral

Output Connector J2 Molex pn. 09-65-2068	
Pin	Single Output
1	+V1
2	+V1
3	+V1
4	RTN
5	RTN
6	RTN

Fan Connector J3 Molex pn. 22-04-1021	
Pin	Function
1	Fan + (12V)
2	Fan -

Signal Connector J4 JST PN B10B-PHDSS			
Pin	Single	Pin	Single
1	+Sense	6	Power OK (DC-OK)
2	-Sense	7	+V Standby
3	XP Internal Use	8	+V Standby
4	Inhibit LO	9	-V Standby
5	Inhibit HI	10	-V Standby

Notes:

1. All dimensions in inches (mm).
2. Tolerance .xx = ± 0.02 (0.50); .xxx = ± 0.01 (0.25)
3. Weight: 0.71 lbs (320g) approx.
4. J1 mates with Molex Housing PN 09-50-1031, J2 mates with Molex Housing PN

09-50-1061 and both with Molex series 5194 crimp terminals. J3 mates with Molex Housing PN 22-01-1024 and with Molex series 5103 crimp terminals. J4 mates with JST Housing PN PHDR-10VS and with JST SPHD-001T-P0.5 crimp terminals.

Mechanical Details

Covered Version (-C suffix)

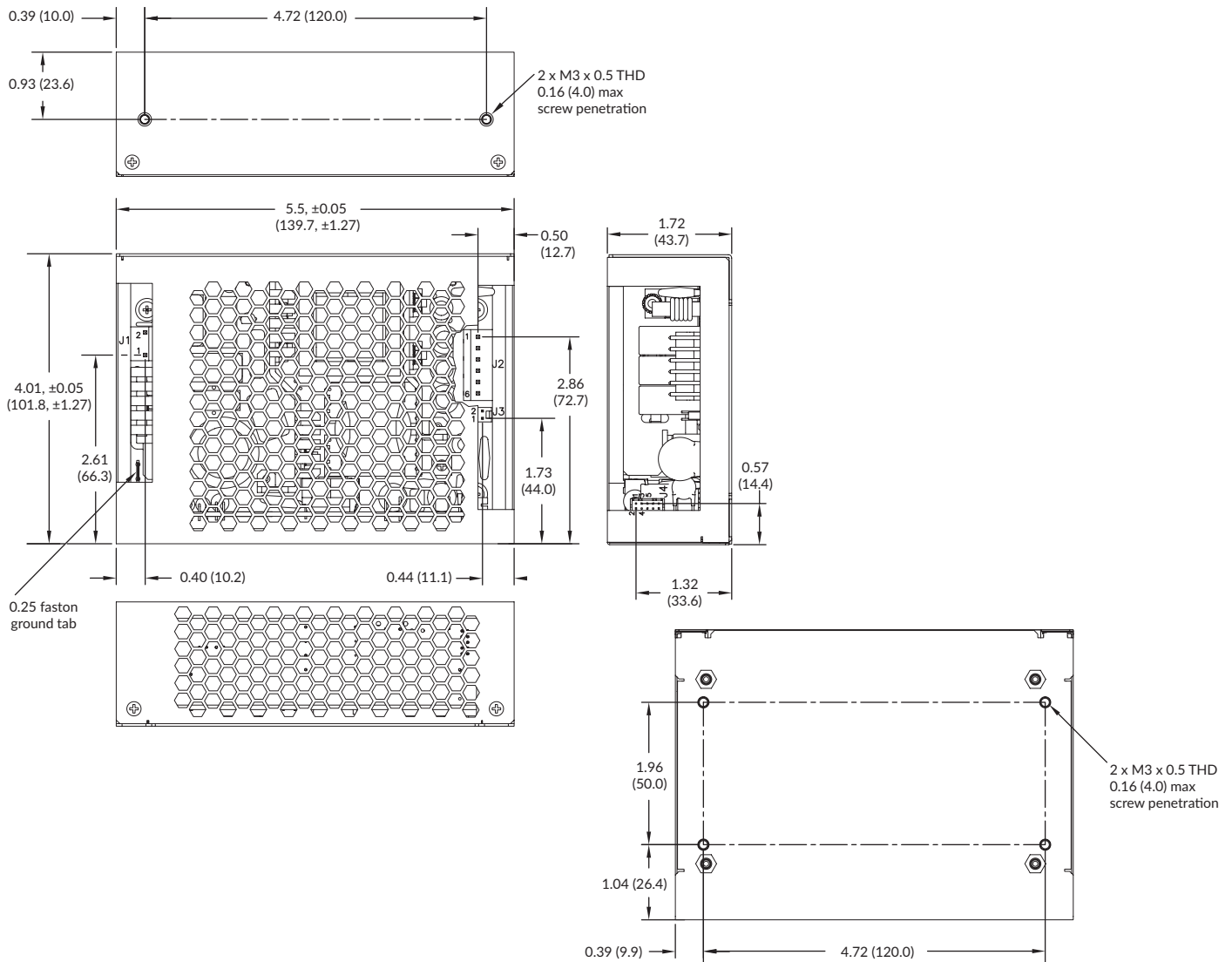

Input Connector J1 Molex pn. 09-65-2038	
Pin	Function
1	Line
2	Neutral

Output Connector J2 Molex pn. 09-65-2068	
Pin	Single Output
1	+V1
2	+V1
3	+V1
4	RTN
5	RTN
6	RTN

Fan Connector J3 Molex pn. 22-04-1021	
Pin	Function
1	Fan + (12V)
2	Fan -

Signal Connector J4 JST PN B10B-PHDSS			
Pin	Single	Pin	Single
1	+Sense	6	Power OK (DC-OK)
2	-Sense	7	+V Standby
3	XP Internal Use	8	+V Standby
4	Inhibit LO	9	-V Standby
5	Inhibit HI	10	-V Standby

Notes:

1. All dimensions in inches (mm).
2. Tolerance .xx = ±0.02 (0.50); .xxx = ±0.01 (0.25), except where shown
3. Weight: 1.08 lbs (490 g) approx.
4. Derate to 150W when convection cooled.

5. J1 mates with Molex Housing PN 09-50-1031, J2 mates with Molex Housing PN 09-50-1061 and both with Molex series 5194 crimp terminals. J3 mates with Molex Housing PN 22-01-1024 and with Molex series 5103 crimp terminals. J4 mates with JST Housing PN PHDR-10VS and with JST SPHD-001T-P0.5 crimp terminals.

Mechanical Details

Top Fan Version (-TF suffix)

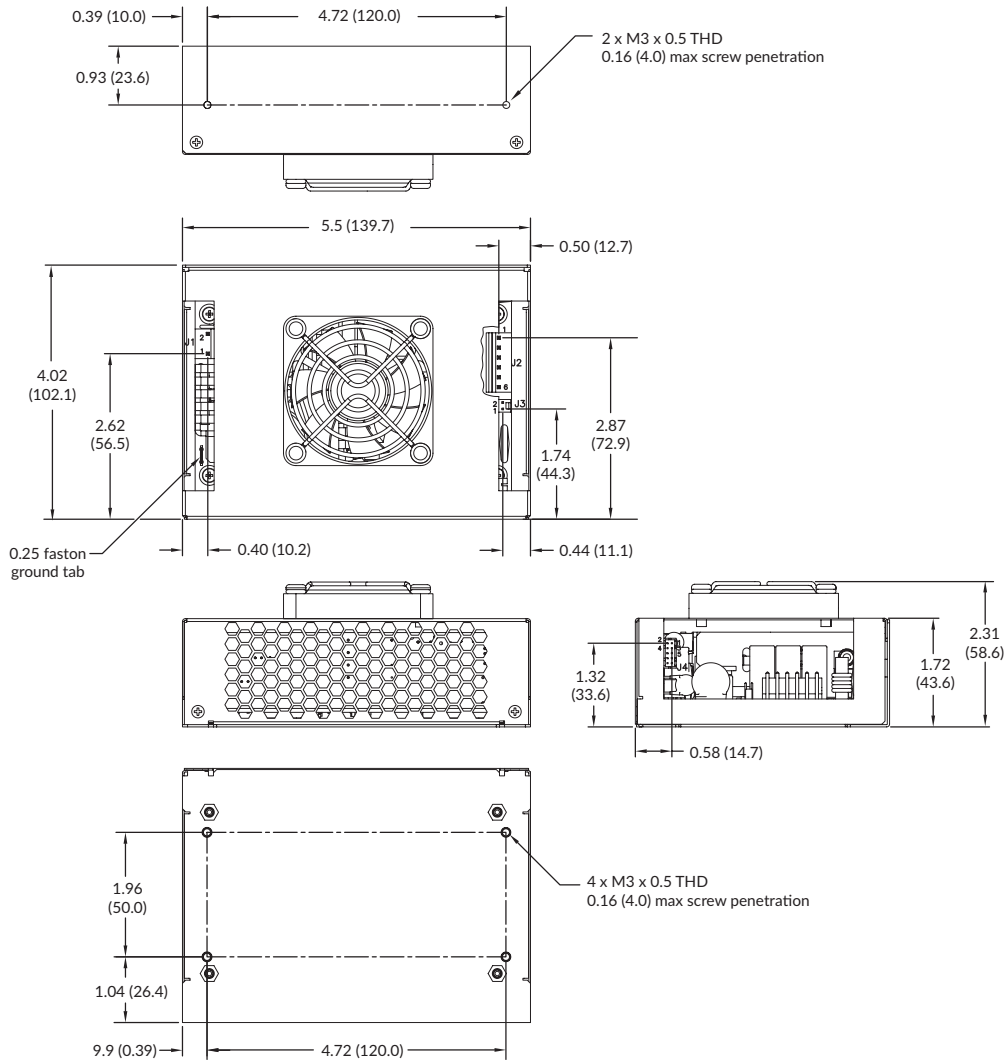

Input Connector J1 Molex pn. 09-65-2038	
Pin	Function
1	Line
2	Neutral

Output Connector J2 Molex pn. 09-65-2068	
Pin	Single Output
1	+V1
2	+V1
3	+V1
4	RTN
5	RTN
6	RTN

Fan Connector J3 Molex pn. 22-04-1021	
Pin	Function
1	Fan + (12V)
2	Fan -

Signal Connector J4 JST PN B10B-PHDSS			
Pin	Single	Pin	Single
1	+Sense	6	Power OK (DC-OK)
2	-Sense	7	+V Standby
3	XP Internal Use	8	+V Standby
4	Inhibit LO	9	-V Standby
5	Inhibit HI	10	-V Standby

Notes:

1. All dimensions in inches (mm).
2. Tolerance .xx = ±0.02 (0.50); .xxx = ±0.01 (0.25)
3. Weight: 1.17 lbs (530 g) approx.
4. J1 mates with Molex Housing PN 09-50-1031, J2 mates with Molex Housing PN

09-50-1061 and both with Molex series 5194 crimp terminals. J3 mates with Molex Housing PN 22-01-1024 and with Molex series 5103 crimp terminals. J4 mates with JST Housing PN PHDR-10VS and with JST SPHD-001T-P0.5 crimp terminals.

Mechanical Details

End Fan (-EF suffix)

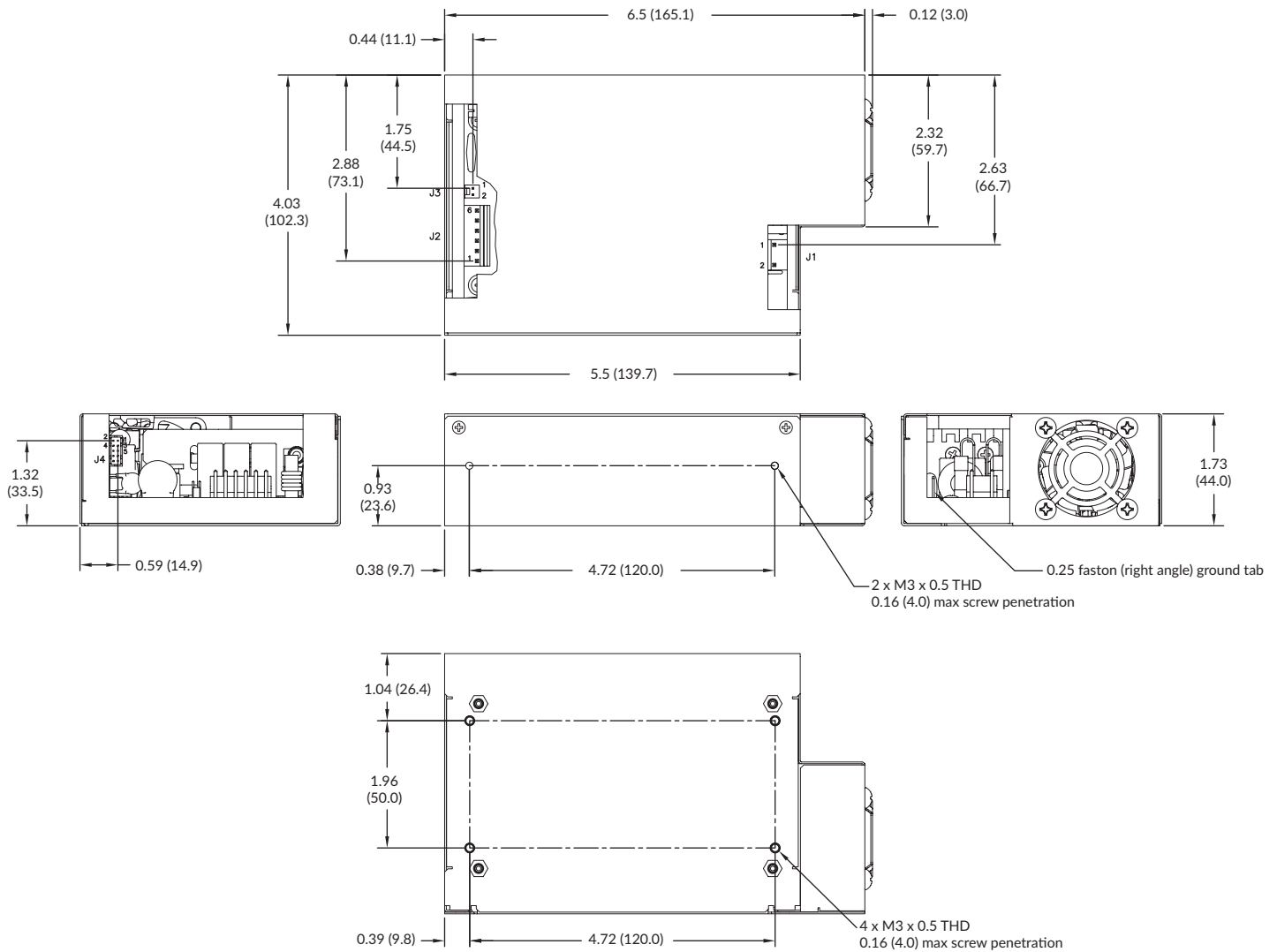

Input Connector J1 Molex pn. 09-65-2038	
Pin	Function
1	Line
2	Neutral

Output Connector J2 Molex pn. 09-65-2068	
Pin	Single Output
1	+V1
2	+V1
3	+V1
4	RTN
5	RTN
6	RTN

Fan Connector J3 Molex pn. 22-04-1021	
Pin	Function
1	Fan + (12V)
2	Fan -

Signal Connector J4 JST PN B10B-PHDSS			
Pin	Single	Pin	Single
1	+Sense	6	Power OK (DC-OK)
2	-Sense	7	+V Standby
3	XP Internal Use	8	+V Standby
4	Inhibit LO	9	-V Standby
5	Inhibit HI	10	-V Standby

Notes:

- All dimensions in inches (mm).
- Tolerance .xx = ±0.02 (0.50); .xxx = ±0.01 (0.25)
- Weight: 1.32 lbs (600 g) approx.
- J1 mates with Molex Housing PN 09-50-1031, J2 mates with Molex Housing PN

09-50-1061 and both with Molex series 5194 crimp terminals. J3 mates with Molex Housing PN 22-01-1024 and with Molex series 5103 crimp terminals. J4 mates with JST Housing PN PHDR-10VS and with JST SPHD-001T-P0.5 crimp terminals.

Thermal Considerations

In order to ensure safe operation of the PSU in the end-use equipment, the temperature of the components listed in the table below must not be exceeded. Temperature should be monitored using K type thermocouples placed on the hottest part of the component (out of direct air flow). See below for component locations.

Temperature Measurements	
Component	Max. Temperature °C
T1 Coil	120°C
L3 Coil	120°C
Q1 Body	120°C
Q3 Body	120°C
C6	105°C
C23	105°C

Service Life

The estimated service life of the GCS265 Series is determined by the cooling arrangements and load conditions experienced in the end application. Due to the uncertain nature of the end application this estimated service life is based on the actual measured temperature of a key capacitors with in the product when installed by the end application. The worst case of the two figures should be taken as the indicative service life in 24/7 operation.

The graphs below expresses the estimated lifetime of a given component temperature and assumes continuous operation at this temperature.

Estimated Service Life vs Component Temperature

